

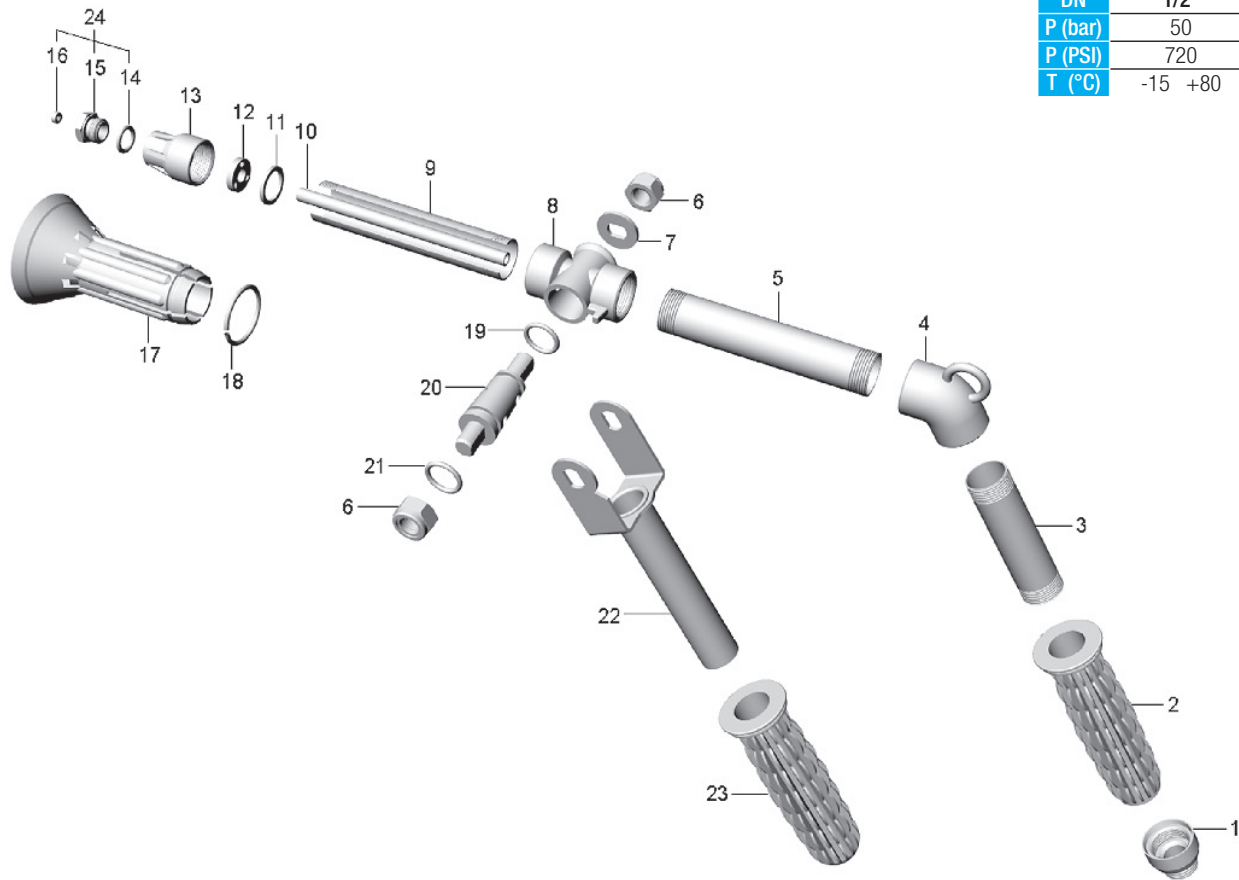

Condizioni di esercizio
Work conditions

DN	1/2"
P (bar)	50
P (PSI)	720
T (°C)	-15 +80



POS.	CODICE / CODE	DENOMINAZIONE	DENOMINATION	MATERIALE	MATERIAL
1	TOIR 1150 015 026	RACCORDO FINALE 1/2"	FINAL CONNECTION 1/2"	OTTONE UNI EN 12164	UNI EN 12164 BRASS
2	SPIR 1150 015 025	MANOPOLA Ø24	HAND GRIP Ø24	PLASTICA	PLASTIC
3	TAIR 1150 015 024	TUBO Ø24 × 1 × L120 - 2 filetti	PIPE Ø24 × 1 × L120 - 2 threads	ACCIAIO INOX AISI 304	AISI 304 STAINLESS STEEL
4	FOIR 1155 015 015	CORPO MITRA	BODY SPRAY GUN	OTTONE UNI EN 1982	UNI EN 1982 BRASS
5	TAIR 1155 015 029	TUBO Ø24 × 1 × L220 - 2 filetti	PIPE Ø24 × 1 × L220 - 2 threads	ACCIAIO INOX AISI 304	AISI 304 STAINLESS STEEL
6	DAAC 0092 150 006	DADO AUTOBLOCCANTE M12	SELF LOCKING NUT M12	ACCIAIO ZINCATO	ZINC PLATED STEEL
7	ROAC 1140 010 014	RONDELLA Ø25 × 12 × 2,5	WASHER Ø25 × 12 × 2,5	ACCIAIO ZINCATO	ZINC PLATED STEEL
8	SOIR 1140 010 001	CORPO	BODY	OTTONE UNI EN 12165	UNI EN 12165 BRASS
9	TAIR 1155 015 009	TUBO Ø24 × 1 × L180	PIPE Ø24 × 1 × L180	ACCIAIO INOX AISI 304	AISI 304 STAINLESS STEEL
10	TOIR 1155 015 008	TUBO Ø8 × 1 × L192	PIPE Ø8 × 1 × L192	OTTONE UNI EN 12168	UNI EN 12168 BRASS
11	TOIR 1170 015 026	RONDELLA Ø23 × 18 × 2	WASHER Ø23 × 18 × 2	OTTONE UNI EN 12168	UNI EN 12168 BRASS
12	TOIR 1140 330 010	CONVOGLIATORE Ø20	CONVEYOR Ø20	OTTONE UNI EN 12164	UNI EN 12164 BRASS
13	SOIR 1170 015 020	TESTA M25×1,5	HEAD M25×1,5	OTTONE UNI EN 12165	UNI EN 12165 BRASS
14	..OR 1130 010 007	OR 115 (Øi 11,91×2,62)	O RING 115 (Øi 11,91×2,62)	GOMMA NBR 75	NBR 75 RUBBER
15	TOIR 1130 010 005	TESTINA	SMALL HEAD	OTTONE UNI EN 12164	UNI EN 12164 BRASS
16	UGEL B71C 025 000	BUSSOLINA B71C foro 2,5	B71C INSET 2,5 hole	CERAMICA	BAKED CLAY
17	SPIR 1170 015 019	PARASPRUZZO	SPRINKLING-GUARD	NYLON + VETRO	NYLON + GLASS
18	SEEG 1170 015 028	ANELLO DI ARRESTO UNI 7433	STOP RING UNI 7433	ACCIAIO ZINCATO	ZINC PLATED STEEL
19	..OR 1027 015 002	OR 117 (Øi 13,10×2,62)	O RING 117 (Øi 13,10×2,62)	GOMMA NBR 75	NBR 75 RUBBER
20	TOIR 1140 010 003	MASCHIO	SHUTTING CONE	OTTONE UNI EN 12164	UNI EN 12164 BRASS
21	..OR 1070 006 004	OR 121 (Øi 15,88×2,62)	O RING 121 (Øi 15,88×2,62)	GOMMA NBR 75	NBR 75 RUBBER
22	SAIR 1155 015 027	FORCELLA	FORK	ACCIAIO ZINCATO	ZINC PLATED STEEL
23	SPIR 1155 015 028	MANOPOLA CIECA Ø22	BLIND HAND GRIP Ø22	PLASTICA	PLASTIC
24	UGEL U71C 025 000	UGELLO U71C foro 2,5	U71C NOZZLE 2,5 hole		